

1438
1438M

Emergency Exit Hardware

Introduction

The Briton 1438 push pad emergency exit device with single point rim latch is suitable for single doors up to 1300mm wide making them an ideal solution for offices, factories and flats. Products conforming to EN 179 are only intended for use by personnel who are fully aware of escape routes and have been trained to operate these devices.

IMPORTANT NOTE:

If you are in any doubt at all, ALWAYS use products that conform to EN 1125.

Features & Functions

- Surface mounted push pad operated rim latch with single point latching
- Designed to satisfy emergency exit applications
- Tested in excess of 200,000 cycles
- Suitable for all single doors and in combination with Briton 372 on the active leaf of rebated double doors
- Two-point locking for extra security
- Site reversible for left or right hand
- All versions supplied with fixings and self-adhesive "Push to Open" signage



1438.SE



certifire



Certification

UKCA Marked to EN 179 (1121-CPR-UK-ABB7573)

CE Marked to EN 179 (2812-CPR-ABB0020)

Certifire Approved (CF5506)

Fire tested to EN 1634-1 for use on fire doors up to 2hr timber / 2hr steel

Environmental Product Declaration in accordance with ISO 14025 and EN 15803

DoP available at www.britondops.co.uk

Emergency Exit Rim Latch Briton 1438

Product features	Product references	
	1438	1438M
UKCA & CE marked	■	■
Panic exit device to EN 1125		
Emergency exit device to EN 179	■	■
Device type	Push pad	Push pad
Locking points	Single point rim latch	Single point rim latch
Suitable for timber or metal doors	Timber	Metal
Suitable for single doors	■	■
Suitable for double door combinations	✱	✱
Min. / Max. door width (per leaf)	n/a	n/a
Push bar cut on site	n/a	n/a
Site reversible	■	■
Alarm activation		
Dogged hold-open facility		
Finishes available	SE	SE
CE Classification	376B1342BA	376B1342BA

ADDITIONAL OPTIONS
 1413.LE OAD Lever Operated
 1413.KE OAD Knob Operated
 OG500.50 Rim Cylinder
 9260 Digital Code Lock

■ Standard □ Available as an option/variant

✱ Used in combination with Briton 372 vertical bolt device and double door strike on rebated double doors where the 1438 device is fitted to the first opening leaf.

Briton 1438

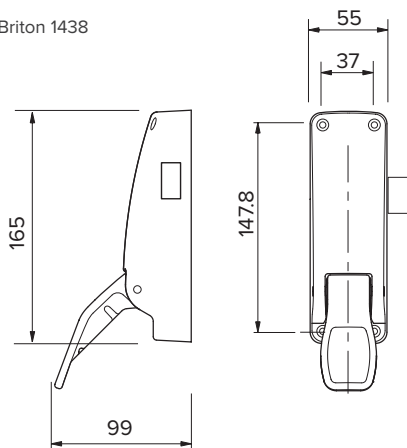

All dimensions are in mm

Rebated double doors

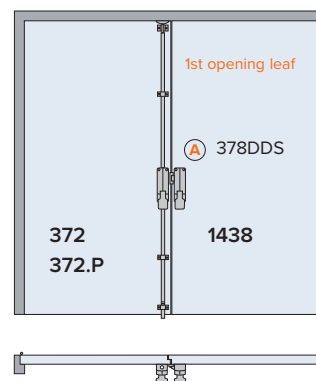

Part No.	Part No.
Briton 372	Briton 1438
	Briton 378DDS

Finishes

Available in sprayed silver



Panic Exit Hardware

Accessories

A range of additional or alternative components is available for the 370 Series of exit hardware.



376ELTS - Extra long top shoot

Extra long top shoots are designed to be used on doors that require the push bar to be in a lower position e.g schools. It can also be used on doors that exceed 2500mm up to 3350mm high.



376FFKP - Flush face keeper plate

For flush fitting doors and frames a surface mounted flush face keeper plate can be used to secure the bolt.



378DDS - Double door strike

For use on double rebated doors with a rim panic latch on the first opening leaf and a vertical bolt on the second opening leaf.



370PLTM Pullman Latches

Pullman latches offer increased security and provide a smooth latching action, a quiet alternative to the traditional top trip catch.

Pullman Fixing Kits are supplied separately to upgrade existing installations.

Fixings

All Briton exit devices are supplied with self-tapping screws suitable for timber and metal doorsets.

For customers who prefer machine screws, alternative fixing packs are available.



379MDS Metal box strike

For use with 379.N or 389.N mortice nightlatch.

370 Series



378MDS metal door strike

Metal door strike for use with 378 or 1438 rim devices on single doors, or on the first opening leaf of a double rebated application.



376MDS metal door strike

For vertical panic bolts. Comprises 2 strike plates and 1 trip plate to activate the top tripper.

Installation and Maintenance

Panic and emergency exit hardware play a vital role in a building's escape route and it is important that these devices are installed, inspected and maintained regularly to ensure safety at all times.

Exit hardware

All panic hardware installation will be operated by a horizontal "Push bar" or "Touch bar" which runs across the width of the door. The operating bar will be used to operate anything from a single rim latch to multipoint side or top/bottom latches.

Top and bottom latches on Briton 370 panic exit hardware are operated by solid rods which are connected to the operating bar.

INSTALLATION

Comprehensive installation instructions are provided with all Briton 370 Series exit devices. To maximise the efficiency and life cycle of these products it is important to follow the installation guidance carefully to achieve an accurate installation. To meet the European standard, the door and frame must be in a good condition, correctly hung and not distorted. We recommend verifying the door construction before installation to ensure it allows for the use of the device.

MAINTENANCE AND CHECKING FUNCTION

In view of the important role the panic and emergency exit device plays in maintaining the safety and security of your building and its occupants, it is recommended that routine maintenance checks are carried out at intervals of not more than 1 month by the occupier or their approved representative.

Types of maintenance

Much of the routine maintenance recommended consists of a combination of visual and mechanical checks, cleaning and lubrication. Look out for the icons opposite which provide a 'quick glance' reminder of the maintenance required.

Visual checks

Primarily making a visual check on the product and surrounding door/frame looking for wear, damage, and general condition.



Functional checks

Consists of checking that the product operates properly without any binding or undue force required. Check that any seals or weatherstripping do not inhibit correct operation of the door.



Check fixings

Fixings need to be checked regularly and tightened when necessary. Check that no projection of fixings prevents the door from swinging freely.



Lubricating

Some products will benefit from periodic lubrication using a light machine oil or as instructed.



Cleaning

Build up of grease, dust and harmful chemicals should be removed to prevent corrosion and maintain the product finish.



Exit Hardware Maintenance

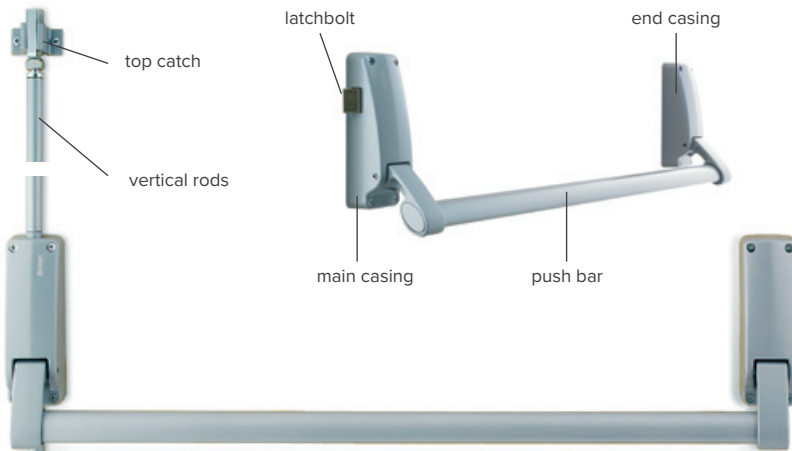

MONTHLY CHECKS

Briton panic exit devices must be fitted to comply with the requirements of EN 1125 which states that the device should be easily operated by hand or body pressure in a panic situation. We suggest the following checks be made on all panic and emergency exit hardware:

- Inspect and operate the device to ensure all the components are in satisfactory working condition and operate as follows:
 - a. After being pushed the 'Push bar' or 'Push Pad' should return automatically to its initial position.
 - b. When pushed from the end casing side (hinge side of door) the latchbolt(s) should completely withdraw from their strikers as if it were pushed from the main casing side.
- **IMMEDIATE EXIT MUST BE PERMITTED.**
 - c. With the door closed, the latchbolts should be fully engaged into their strikers. They should not withdraw if pushed but should only withdraw if operated by the 'Push bar'.
 - d. If necessary upper and lower pullman latches can be adjusted to ensure the accuracy of latching.
- Inspect strikers and ensure they are clean and free from obstruction.
- Ensure the door closes fully into the frame and there are no obstructions.
- Check that the door has not become distorted in any way. If the door does not meet the frame stops and cannot be pulled in by the door closer the door may need to be replaced.
- Check that the door hinges are operating smoothly and lubricate if necessary.
- Check that the latches are operating freely. If necessary remove the end box covers and/or pullman latch covers and lubricate if necessary.
- Check that all fixings are tight.

To assist in keeping these products fully operational spare part kits are available.

If problems persist and for some reason the panic device does not operate properly, consult your approved supplier or contact the Allegion Customer Care Team on 0330 8080 617

